

Data Sheet for Joysticks

3D Finger Joystick

SpaceMouse® Module



- Revolutionary, intuitive control of complex 3D movements
- Special industrial module: dust and splash water protection (IP54), long-lived handle material, strong spring tension and small dead zone
- 6 axis / 6 degrees of freedom (6DoF)
- Optoelectronic sensor, contactless and linear
- Optional UART (serial) or USB interface

The robust and high-precision SpaceMouse® Module is the ideal man-machine-interface for industrial applications. Its sensor is used worldwide in millions of 3D mice, enabling manipulations with up to 6 degrees of freedom.

To fit the different needs of industry compared to desktop applications, spring tension, dead zone and controller cap material are optimized and the sealing is improved, introducing resistance to dust and splash water. It also operates independently of ageing, temperature and static magnetic fields. Combined with its slimline mounting depth, it is the ideal choice for many industrial applications, from laboratories to production plants, e.g. in the robotics and automation sector.

The SpaceMouse® Module is available with a USB or serial (UART) interface. A rubber ring is available as separate accessory for increased adhesion with plastic foils.

Technical Data	UART Interface (art.-nr. 131034)	USB Interface (art.-nr. 131002)
Electrical		
Sensor	Optoelectronic	
Digital Resolution	10 bit	
Resolution Translation	250 Increments / mm	
Resolution Rotation	170 Increments / degree	
Data Rate	Max. 100 / s	
Supply Voltage	+3.3 to +5.5 V	5 V ±10 %
Current Consumption	Max. 10 mA	Max. 20 mA
Physical		
Height	52.2 mm	
Max. Ø Cap	53.8 mm	
Weight	60 g	
Ø Installation Cut-Out	40.2 mm	
Thickness of Panel	1 to 5.5 mm	
Installation Depth	15 mm	
Vertical Actuation Force	11.0 N	
Horizontal Actuation Force	7.4 N	
Torque	171 Nmm	
Vertical Displacement	1.5 mm	
Horizontal Displacement	1,5 mm	
Twist & Tilt Angle (cw & ccw)	6°	
Cable Length	200 mm ± 10 mm	1500 mm ±50 mm
Environmental Conditions		
Operating Temperature	0 °C to +50 °C	
Storage Temperature	-30 °C to +70 °C	
Humidity (operating at T≤40°C)	Min. 10 % - Max. 85 % (non condensing)	
Humidity (storage at T≤40°C)	Min. 10 % - Max. 95 % (non condensing)	
Protection Class	IP54	
EMI	EN61000-4-3 (10 V, 10 V/m)	
ESD	EN61000-4-2 / Level 4	

Data Sheet for Joysticks

3D Finger Joystick

SpaceMouse® Module

Table of Contents

1	PRODUCT DESCRIPTION	3
1.1	USAGE NOTES	3
1.2	COMPONENTS	4
1.3	DEFAULT AXIS ORIENTATION	4
2	TESTS	5
2.1	DEGREES OF PROTECTION	5
2.2	TOLERANCE & RELIABILITY	6
2.3	LIFE TEST	6
4	TECHNICAL DRAWING	7
3.1	CASE OUTLINE UART	7
3.2	CASE OUTLINE USB	8
3.3	MOUNTING HOLE	9
5	INTERFACE SPECIFICATION UART	10
5.1	ELECTRICAL	10
5.2	PROTOCOL	11
6	INTERFACE SPECIFICATION USB	13
6.1	ELECTRICAL & PROTOCOL	13

Data Sheet for Joysticks

3D Finger Joystick

SpaceMouse® Module

1 PRODUCT DESCRIPTION

1.1 USAGE NOTES

The controller cap mounted on the measuring system can be moved in 6 degrees of freedom: Horizontal shift in x-direction and z-direction, vertical shift in y-direction, rotational tilt around x-axis and z-axis, plus twist around y-axis. Manipulation in several axes can be done simultaneously. For definition of axis orientation, please refer to chapter 1.3 „DEFAULT AXIS ORIENTATION“.



The SpaceMouse® Module **UART** communicates via serial interface (UART = Universal Asynchronous Receiver Transmitter). The signal levels are 0 Volt (logic 0) or VCC (logic 1), hence they are not RS232 compliant. For further details, please refer to chapter 5 „UART INTERFACE SPECIFICATION“.

The SpaceMouse® Module **USB** is recognized by the operating system as a standard joystick with 6 axes. The USB protocol follows the HID spec rev. 1.11, so no additional driver is needed. The following operating systems are supported:

- Windows 10
- Windows 8
- Windows 7
- Windows Vista
- Windows XP SP2
- Linux with USB host support
- Other systems supporting USB joysticks

For further details, please refer to chapter 6 „USB INTERFACE SPECIFICATION“.

ACCESSORIES

The SpaceMouse® Module comes with an ABS cap. If bigger adhesion with plastic foils or gloves can be reached by imposing our elastomer ring on top of the cap.



This accessory is not part of the scope of delivery and needs to be ordered separately (Art. 134818).

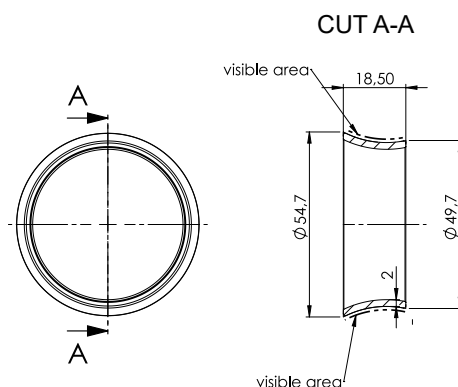

Data Sheet for Joysticks

3D Finger Joystick

SpaceMouse® Module

1 PRODUCT DESCRIPTION

1.2 COMPONENTS

(shown for UART Module)

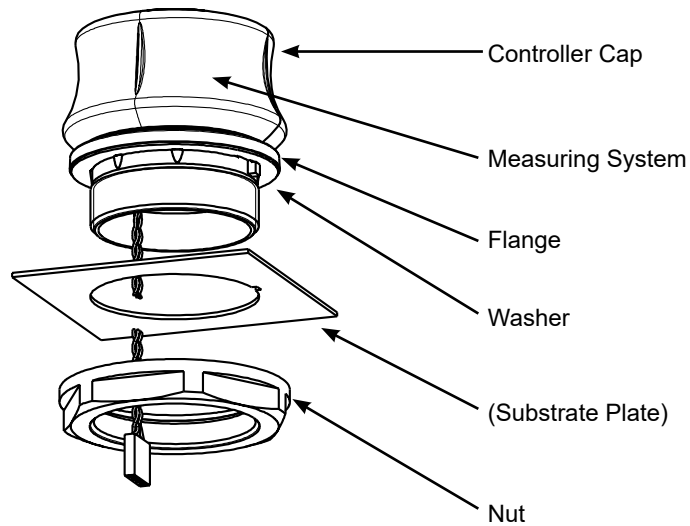

1.3 DEFAULT AXIS ORIENTATION

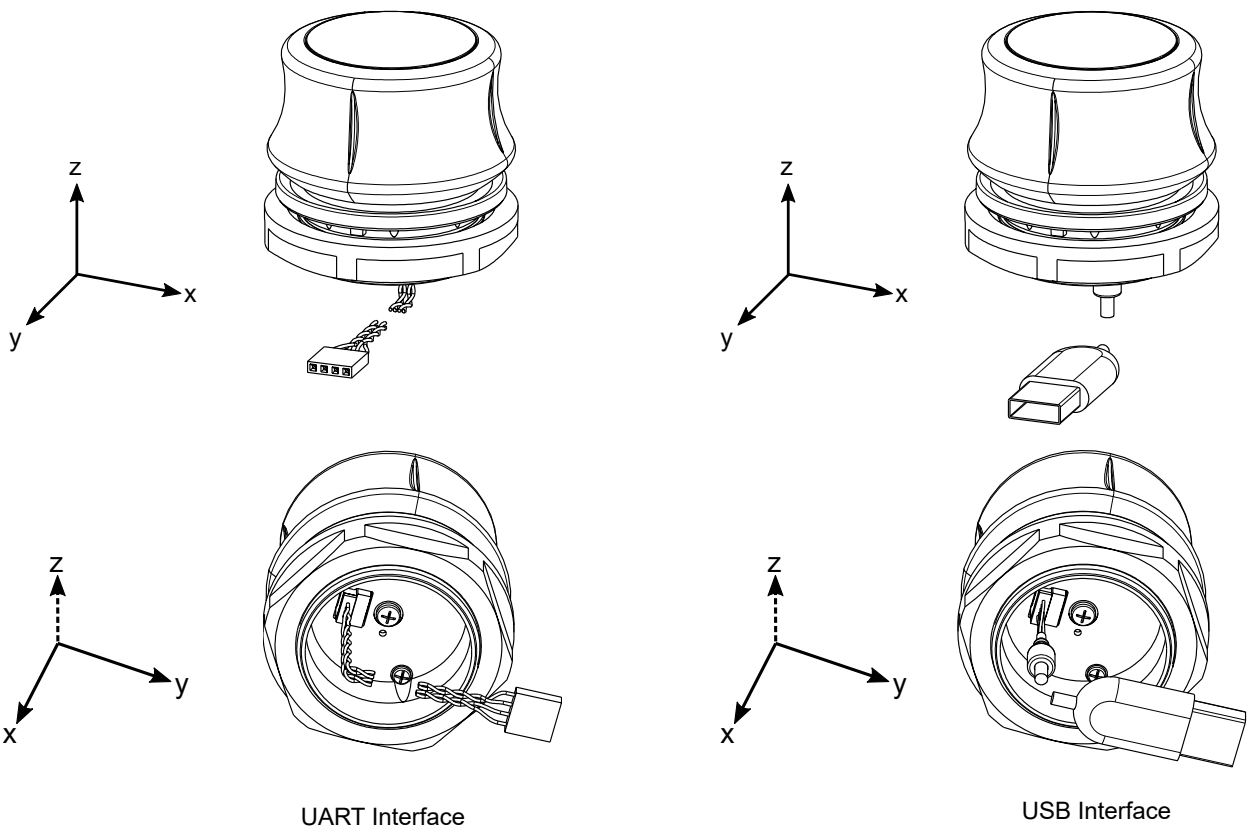

Data Sheet for Joysticks

3D Finger Joystick

SpaceMouse® Module

2 Tests

All tests and measurements were conducted under the following conditions unless otherwise specified:

- Temperature: 23 °C (73.4 °F) ± 10 °C (50 °F)
- Humidity: 65 % ± 20 %RH
- Atmospheric Pressure: 86 kPa (860 mBar) ~ 106 kPa (1060 mBar)

2.1 DEGREES OF PROTECTION

2.1.1 Tightness

Protection Class at least IP54

Item	Test Conditions	Specifications
First Digit: 5 (Dust protected)	Ingress of dust is not entirely prevented, but it must not enter in sufficient quantity to interfere with the satisfactory operation of the equipment; complete protection against contact	
Second Digit: 4 (Splashing Water)	Test duration: 5 min. Water volume: 10 l/min. Pressure: 80-100 kN/m ²	Water splashing against the enclosure from any direction shall have no harmful effect.

Mounting conditions must be regarded for achieving this protection class.

2.1.2 PWIS (paint-wetting impairment substances)

Cap with cosmetic treatment and complete SpaceMouse® Module were tested. No paint wetting impairment substances detected. (PWIS – free).

(German: LABS - frei: keine lackbenetzungstörende Substanzen)

Item	Test Conditions	Specifications
Blast Test	Test item is hanging free Indicating substrate: cleaned Al-sheet Gas medium: N2 Blast time: 30 s Paint: Duplicolor 1-0400	Blowing gas blast on test item. Indicating substrate is in discharged gas blast. After blast, indicating substrate is covered with paint. No crater or impurity on painted sheet are accepted.

2.1.3 Fire Protection

For plastic parts (Cap, Insert, Flange): Fire protection classification UL94: at least V1

Data Sheet for Joysticks

3D Finger Joystick

SpaceMouse® Module

2 Tests

2.2 TOLERANCE AND RELIABILITY

Item	Test Conditions	Specifications
Controller Cap lifetime	(1) Operating speed: 2-3 times/s (2) Force applied at center of cap-side: 7.4N ± 0.9N (740gf ±90gf)	Number of actuations: 1,000,000 times No functional defects for the cap actuation
Drop test (only for reference)	(1) Height: 100cm (2) Floor surface: Steel or concrete (3) Direction: 5 faces, except cable face (4) Number of drops: 5 (one drop per face)	No cracks or breakage (excl. cosmetic scratches). No functional defects for the buttons and Controller Cap actuation. Pop out of buttons and cap-insert is accepted when they can be pushed in again without impact to function

2.3 LIFE TEST

Item	Test Conditions	Specifications
Burn-In Test	Expose device 24hrs to a temperature of 45°C	No functional defects, no cosmetic degeneration
Mean Time Between Failure	30 EA for 84 day burn-in at 45°C (can differ depending on the available resources at test lab.)	Confidence Level 80% MTBF = 150.000 hours

3 Technical Drawing

3.2 CASE OUTLINE - USB Interface

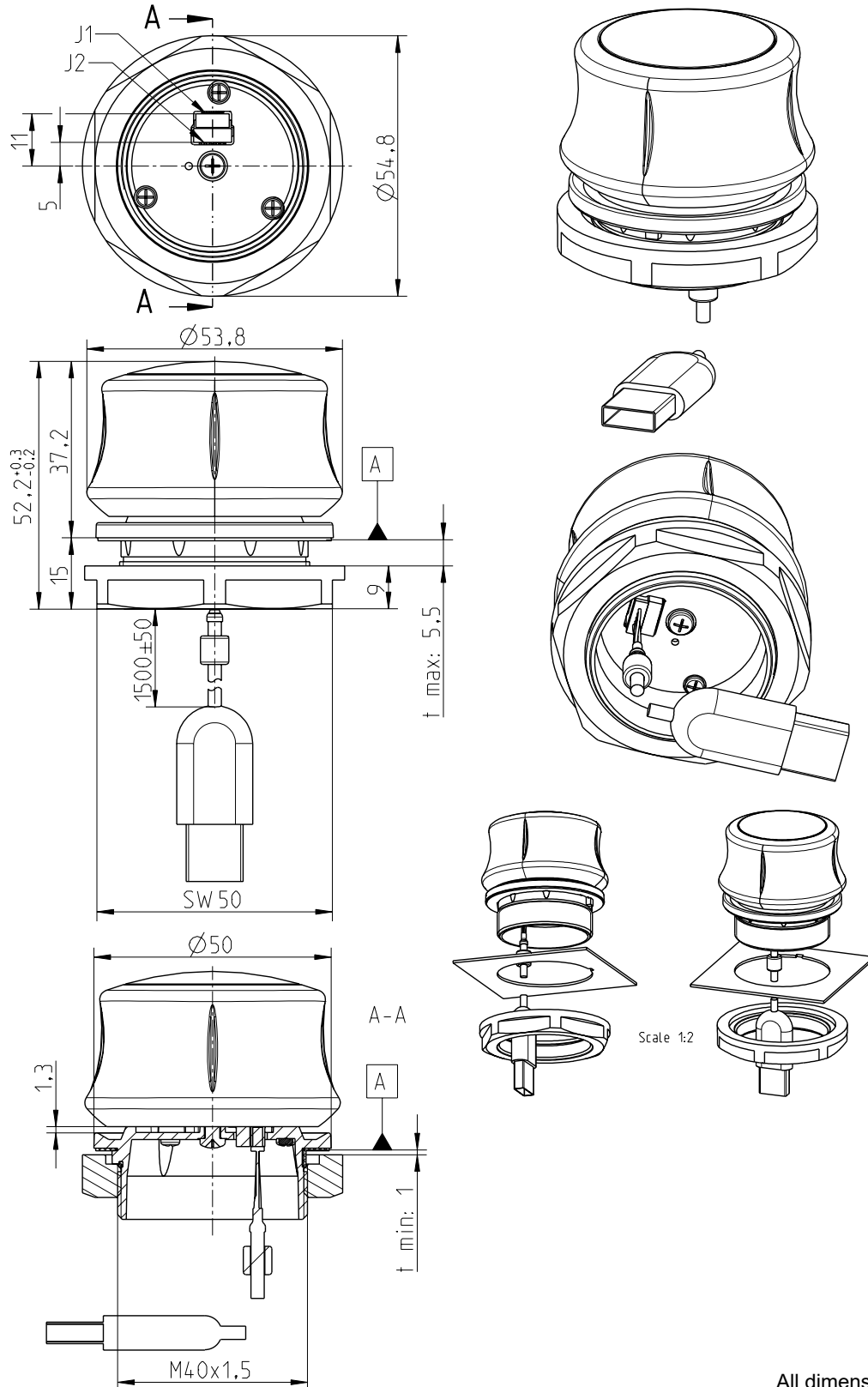

All dimensions in mm

3 Technical Drawing

3.3 MOUNTING HOLE

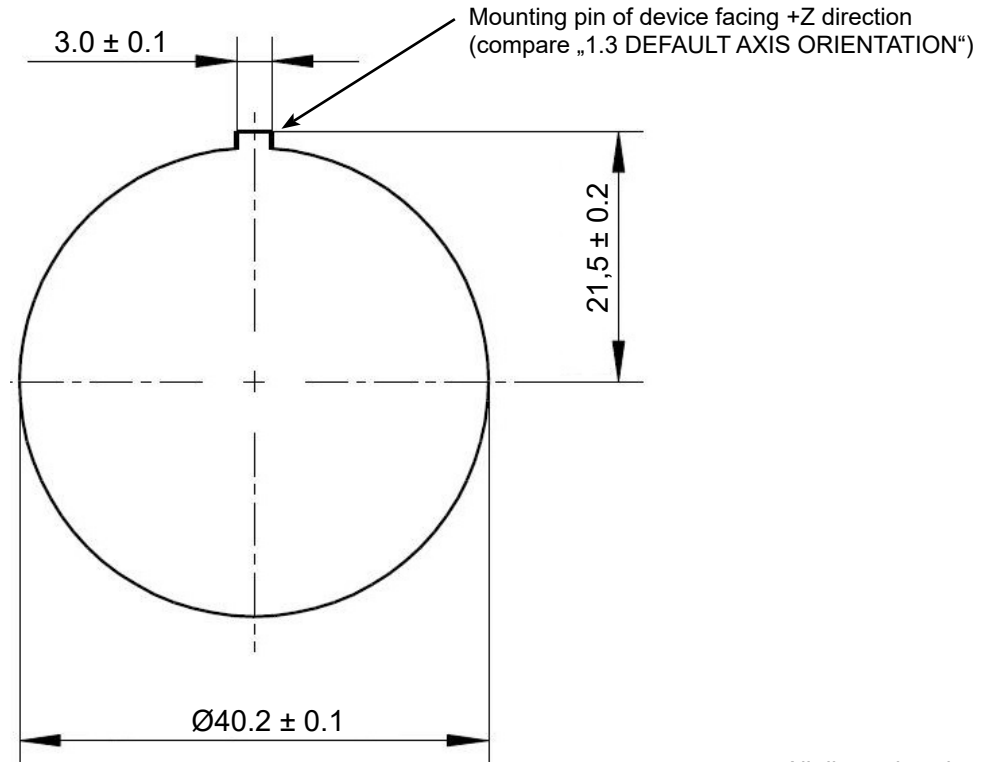

All dimensions in mm

SpaceMouse®Module UART Interface
Article number 131034

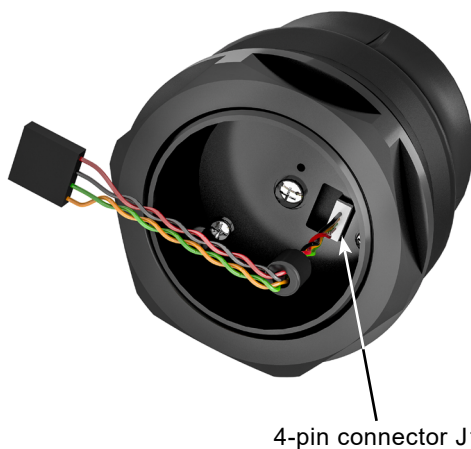

With art. nr. 131034 a 4 core cable (length 20 cm) is included. For details see section 5.1.2.

SpaceMouse®Module USB Interface
Article number 131002



With art. nr. 131002 a USB cable (length 1.5 m) with type A connector is included

5 UART INTERFACE SPECIFICATION

5.1 ELECTRICAL

5.1.1 Data interface (UART) settings

The device communicates via serial interface (UART = Universal Asynchronous Receiver Transmitter). The signal levels are 0 Volt (logic 0) or VCC (logic 1), hence they are not RS232 compliant.

UART settings

Baud rate	38400
Data bits	8
Parity	none
Stop bits	1
Data rate	max. 100 / s

5.1.2 4-Pin Connector J1

The UART Module has a 4-pin male connector with 1,0 mm grid pattern. The length of the provided 4-core twisted pair cable is 200 mm ± 10 mm. Cable connector: JST SHR-04V-S-B with crimp contact SSH-003T-P0.2 Connector on the module: JST BM04B-SRSS-TB

Pin	Function	Wire Color
1	VCC +3.3 V to +5.0 V	red
2	TxD (output)	green
3	RxD (input)	orange
4	GND	black

5.1.3 Cable

For connector to UART Module, please refer to chapter 5.1.2 „4 Pin Connector J1“

The connection to a console is achieved by a 4-pin female connector with 2.54mm grid pattern.

Pin	Function	Wire Color
1	VCC +3.3 V to +5.0 V	red
2	GND	black
3	TxD (output)	green
4	RxD (input)	orange

5 UART INTERFACE SPECIFICATION

5.2 PROTOCOL

The UART Module listens to the following commands:

Function	Command	Answer
Data request command	REQUEST_DATA	0xAC
Zero command	SET_ZERO_POSITION	0xAD
Start auto-data	AUTO_DATA_ON	0xAE
Stop auto-data	AUTO_DATA_OFF	0xAF

5.2.1 Command structure

All commands are single byte commands with MSB set to logic 1.

Bit7	Bit6	Bit5	Bit4	Bit3	Bit2	Bit1	Bit0
1	X	X	X	X	X	X	X

Each command is acknowledged by a response, each response of the 3D-Sensor is terminated by an end-byte 0x8D (MSB is set).

5.2.2 UART commands

SET_ZERO_POSITION

Function: sets the current position of the device as zero-position

Command: 173 (0xAD)

Returns: 0xAD 0x8D

During power-up of the device, the current position of the device is also set as the zero-position.

AUTO_DATA_ON

Function: starts automatic transmission of data (30ms intervals)

Command: 174 (0xAE)

Returns: 0xAE 0x8D

AUTO_DATA_OFF

Function: stops automatic transmission of data

Command: 175 (0xAF)

Returns: 0xAF 0x8D

REQUEST_DATA

Function: requests position data from the 3D-Sensor

Command: 172 (0xAC)

Returns: 16 bytes data

Structure: B1 B2 ... B16

5 UART INTERFACE SPECIFICATION

Byte 1: start-byte 0x96 (150 decimal); every data set starts with this byte
Byte 2: high byte of X value
Byte 3: low byte of X value
Byte 4: high byte of Y value
Byte 5: low byte of Y value
Byte 6: high byte of Z value
Byte 7: low byte of Z value
Byte 8: high byte of A value
Byte 9: low byte of A value
Byte 10: high byte of B value
Byte 11: low byte of B value
Byte 12: high byte of C value
Byte 13: low byte of C value
Byte 14: high byte of Checksum
Byte 15: low byte of Checksum
Byte 16: end-byte 0x8D; every response ends with this byte

X, Y, Z, A, B, C values and the Checksum are transmitted as unsigned 14-Bit values. This is due to the fact, that the MSB of payload data is always cleared (logic 0).

Calculating a value:

high byte (X) low byte (X)

14-bit value (unsigned)

$X_{\text{value}} = (\text{high byte (X)} * 128 + \text{low byte (X)}) - 8192$

Transmitted Checksum:

$\text{Checksum}_{\text{trans}} = (\text{high byte (Checksum}_{\text{trans}}) * 128 + \text{low byte (Checksum}_{\text{trans}}))$

Calculating the Checksum:

$\text{Checksum}_{\text{calc}} = (\text{Byte1} + \text{Byte2} + \dots + \text{Byte13}) \& 0x3FFF.$

By masking the Checksum with 0x3FFF (logic AND operation), the value is reduced to a 14-Bit value.

Data Sheet for Joysticks

3D Finger Joystick

SpaceMouse® Module

6 USB INTERFACE SPECIFICATION

6.1 ELECTRICAL & PROTOCOL

6.1.1 Data interface & Protocol

The SpaceMouse® Module USB is designed for USB 1.1 and 2.0. No additional power source is needed. The module acts like a standard USB joystick with 6 axes.

6.1.2 5-Pin Connector J1

The USB Module has a 5-pin male connector with 1,0mm grid pattern.
Cable connector: JST SHR-05V-S-B with crimp contact SSH-003T-P0.2
Connector on the module: JST BM05B-SRSS-TB

Pin	Function	Wire Color
1	Shield	black
2	GND	black
3	VCC +5.0V	red
4	D-	white
5	D+	green

6.1.3 Cable

For connector to USB Sensor Module, please refer to chapter 6.1.2 „5-Pin Connector J1“.

Electrical	Min	Typ	Max
Supply voltage	4.4V	5.0V	5.25V
Supply current			60mA
Suspend current			0.5mA

Pin-out of USB connector

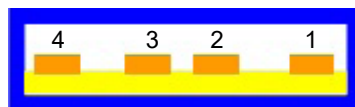

Pin-out of USB cable

USB Plug	Wire Color	Pin Assigned in PCB	Signal
1	red	3	VCC
2	white	4	D- (inversed DATA)
3	green	5	D+ (DATA)
4	black	2	GND
Shell	drain wire	1	Shield

With Art.nr. 131002 a USB cable (length 1,5m) with type A connector is included